

SYSTEM PIONOWY VL

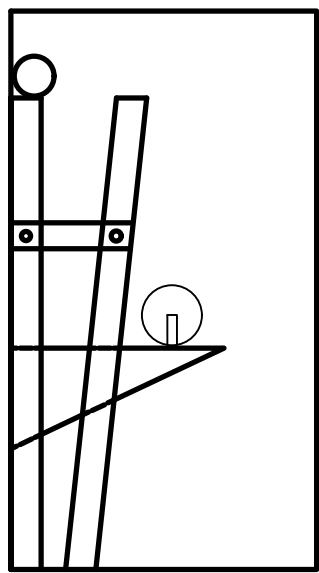

UWAGA !
 Możliwość zastosowania obniżonego wału na blachach trójkątnych

N	H + 30
B1	min. 8 cm KOŁOWRÓT + 8 CM
B2	SILNIK (proponowany przez Bramtech) + 15 cm

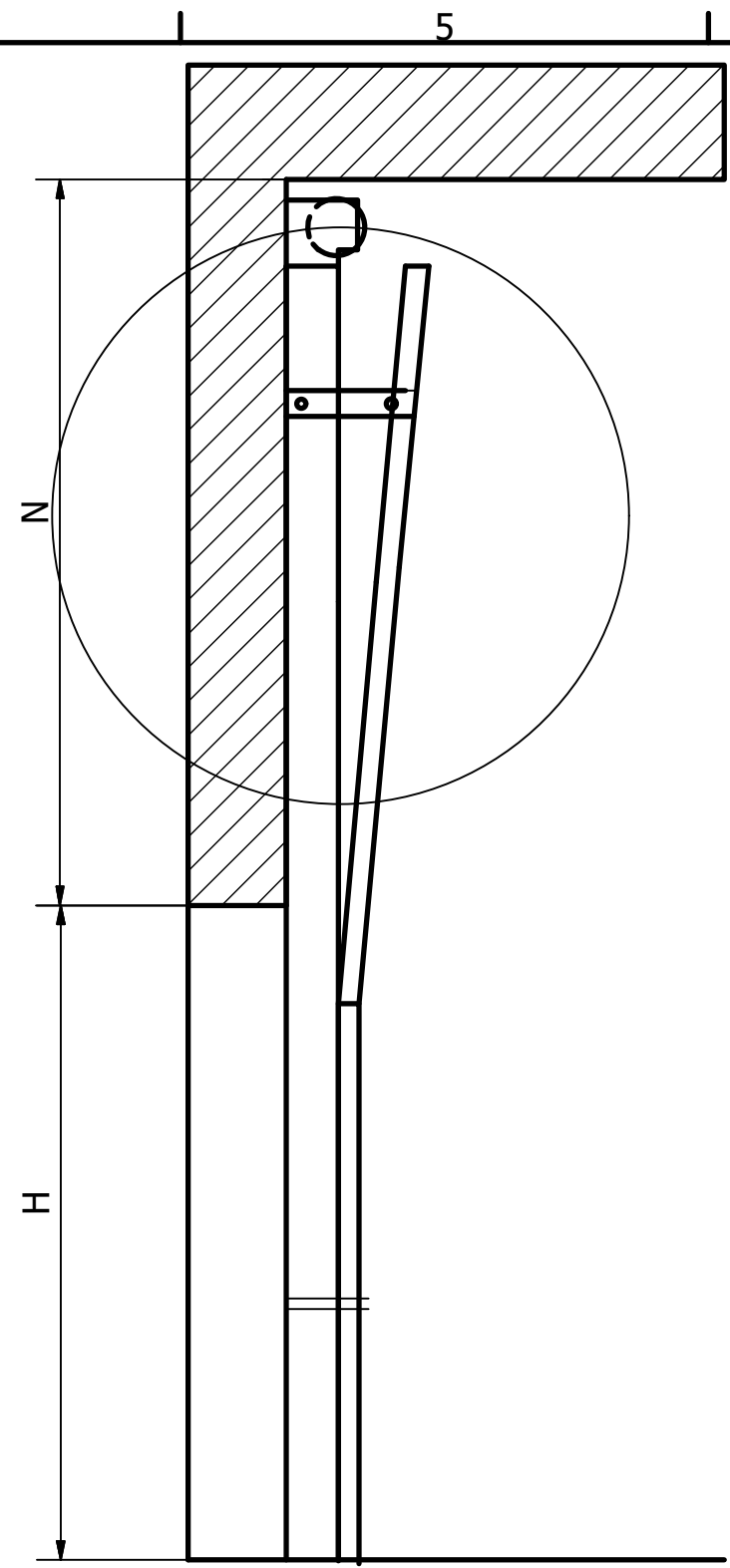